

GMLC-100DS Long Stroke Touch Latch

Features

- Wider vertical adjustment range compared to standard GMLC-100 series
- Adjustment range of counter plate installation position: ± 4 mm vertically and ± 3.5 mm horizontally
- Long stroke
- No handle needed, just push to open/close
- Non magnetic
- Lightly push to open the door. When closing, arm will catch the counter plate and hold the door with a light push
- Installation with rivet is possible
- Passed 100,000 life cycle test



Parts Included

- Truss head tapping screws 4 x 16 (SUS), 4 x 20 (SUS)

Recommended Screws

- M4 pan or truss head screw, No.4 rivet

No.	Part Name	Material	Finish/Colour
①	Body 1	Reinforced Nylon	White
②	Body 2	PBT	
③	Spring	Steel	Coloured Zinc Chromate (Trivalent)
④	Spacer	POM	White
⑤	Counter Plate	PBT	
⑥	Counter Plate	POM	

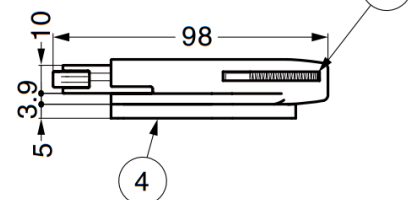
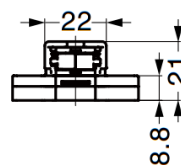
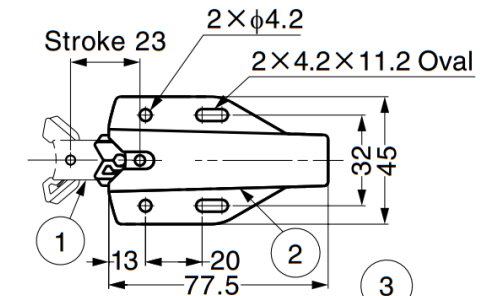
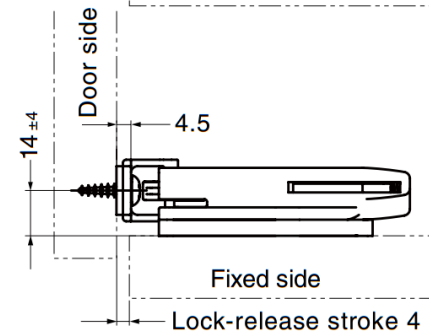
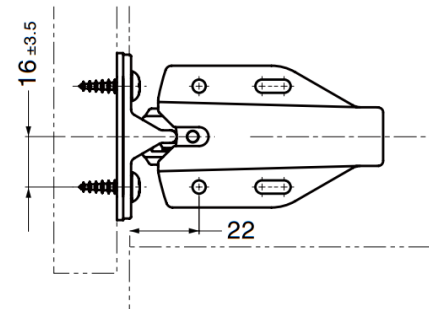
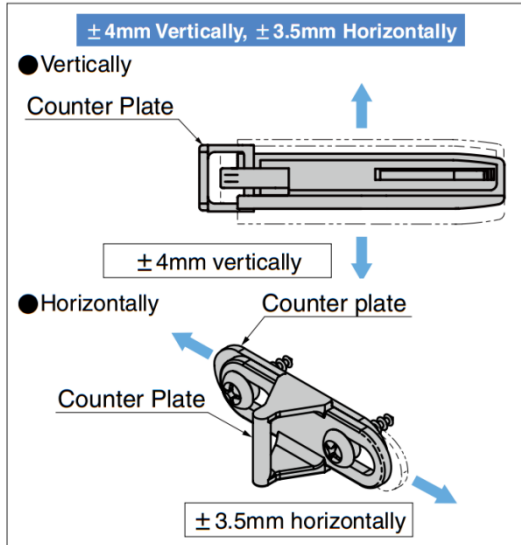

Part No.	Retaining Force		Push Force	
GMLC-100DS-WT	90 N	9.2 kg	14 N	1.4 kg